

Dredging Excavator

Advanced Maritime Equipment



LIEBHERR



Productivity

Working Harder
and Faster



Efficiency

Moving More
for Less



Reliability

Ready to Work
when You Need It





Customer Service

World-Class Support,
Everywhere, Every Day



Safety

Protecting Your Most
Important Assets



Environment

Mining
Responsibly





Productivity



Working Harder and Faster

Liebherr provides a full range of maritime excavator equipped with a complete and unique range of attachments adapted to the customer's application. Operating weights from 100 t to 580 t (121,500 lb to 1,200,000 lb) and power ratings from 565 kW to 2,984 kW (700 HP to 4,000 HP). Liebherr dredging excavators are dedicated to move material in any condition, on seas, oceans or fluvial channels.

Engineered for Maritime Applications

Hydraulic Dredging Control System

The power of the hydraulic technology combined with the high precision from the electronic control contribute to promote energy optimization. The high pressure of the hydraulic excavator system can be used by the barge to offer a uniquely powerful hydraulic source.

Optimized Cycle Times

The Liebherr dredging excavator is equipped with a Close-Loop Swing Circuit. Contrary to machines using open hydraulic circuits, this enables the maximum swing torque whilst retaining the full oil flow for the attachment movement. The use of an independent swing circuit results in faster arm motions even during swing movements contributing to faster cycle times. The mode selector enables the operator to adjust the machine power to match the application for the best performances.

Performance and Accuracy

High Digging Forces

Designed for high-performing mechanical force distribution, the production-tailored attachment delivers high digging and lifting forces. Integrating Liebherr made cylinders, the Liebherr dredging excavator attachment ensures the highest crowd and breakout forces to perform even in the most demanding and intensive job conditions.

Precise Machine Motions

Liebherr dredging excavators design integrates the Litronic Plus electronic control system to allow for easy control even when simultaneous movements are required. The patented Liebherr electronic damping system provides controlled end-cushioning for smooth attachment motions.



Wide Range of Attachments

- From -15 m/-49 ft to -26 m/-79 ft depth
- Adapted for severe marine conditions
- Optimized for maximum bucket capacity, digging depth and dump height
- Special requirement on-demand

Close Loop Swing Circuit for Fast Cycle Times

- Independent hydraulic swing circuit
- High pressure system
- Simultaneous attachment motions possible during swinging

Specific Liebherr Dredging Bucket

- Well-balanced for depth and forces
- Optimized Liebherr GET and wear package according to customer application
- Ensure optimal penetration efficiency
- Single GET hammerless locking system for safe and easy maintenance
- Three tooth profile available for various range of applications

* GET: Ground Engaging Tools



Efficiency



Moving More for Less

Following the Liebherr philosophy of maximizing performance by improving the efficiency of all individual subsystems. The advanced regulation system allows a well balanced energy consumption reducing operating costs per ton. In addition, all components work in optimal performance range that contributes to extend their life for the highest machine availability.

Advanced Energy Optimization

Pontoon Hydraulic Oil Supply

Assuming hydraulic excavators and pontoon vessels are fully integrated systems, hydraulic powerpacks supply hydraulic oil for pontoon vessel consumers through the hydraulic excavator rotary connection.

Independent Cooling System

Oil and water cooling fans are independent and electronically managed. The on-demand cooling control enables to maximize available power for the working process. This technology contributes to maintain sustainable temperature of all the hydraulic components extending their life.

Litronic Plus

The Liebherr-patented Litronic Plus system consists of an intelligent power management system specially developed to optimize electrical, mechanical and hydraulic power distribution. This system encourages fuel efficiency and energy savings while ensuring peak subsystem performance according to immediate working requirements.

Extended Components Lifetime

Liebherr Elastic Foundation Technology

To provide the best working conditions, Liebherr has developed a unique elastic base to absorb all forces with rubber elements. The elastic foundation technology offers the optimum support between the pontoon vessel and the dredging excavator to maximize the life expectancy of the pontoon deck structure and the structural parts of the excavator.



Liebherr Elastic Foundation

- Better operator comfort
- Shock absorption
- Optimal force distribution into the pontoon deck

Front Service Station

- Fuel, engine oil, grease system, hydraulic oil
- Fitted with Wiggins couplings
- Banlaw available as option
- Multiflo Hydrau-Flo as option

Design for Marine Environment

- Special seawater-resistant paint
- Waterproof electric system
- Integrated environmental protections
- Hydraulic cylinders fitted with nickel chrome coating
- Pressurized attachment components (optional)
- Bucket cylinder protection
- Greasing system in stainless steel
- Tailored made pontoon machines



Reliability



Ready to Work when You Need It

With over 50 years of innovative thinking, engineering and manufacturing excellence, Liebherr sets the industry standard for advanced equipment design and technology tools to provide the most up-to-date product responding to the requirements of the dredging customers.

Quality: the Liebherr Trademark

Liebherr Component Integration

As an OEM, Liebherr has built a solid reputation for its development and production of high quality strategic mining components. The Liebherr dredging excavators integrate robust and reliable mining optimized components that are developed, manufactured and controlled by Liebherr ensuring reliability and high performance for the entire machine.

Advanced Hydraulic Oil Filtration

The hydraulic oil filtration systems remove fluid contaminants to offer the highest rate of hydraulic components durability. To maintain oil quality, all return hydraulic oil flow goes through a fine filtration system (15/5 µm) and oil tank is sized to considerably extend the time between service intervals.

Quality Management Continuous Improvement

Liebherr quality begins during machine design and simulations. Liebherr meets the highest standards for special selections of steels and casting materials. Based on the expertise of certified internal auditors and a highly qualified workforce, all manufacturing process steps are devised to provide the most comprehensive control, monitoring and traceability. Liebherr-Mining Equipment Colmar SAS is ISO 9001 certified.

Suit Customer Requirements

Liebherr sales engineer support during the decision-making stage guarantees that the customised product choice perfectly matches customer requirements. To ensure customer satisfaction, the Liebherr products are available in a range of specific configurations. For example, to upgrade the machine for the cold climate environment, to adapt the attachment for an specific application or to increase safety and comfort of the operator. With more than 150 engineers dedicated to develop mining and maritime excavators, Liebherr offers tailored-made solution to meet the clients requirements.



Electric Drive Version

The electric drive system is an efficient alternative to diesel engine allowing:

- Less vibration resulting in higher component lifetime
- Lower maintenance costs
- Less noise pollution
- No exhaust gas emissions
- High motor efficiency

Quality Commitment

- By-pass filtration with water separator

Liebherr Component Integration

Liebherr-made integrated major parts are:

- Hydraulic cylinders
- Hydraulic pumps
- Hydraulic motors
- Pump gears
- Electronics
- Large diameter bearing (swing ring)
- Swing drives



Customer Service



World-Class Support Everywhere, Every Day

A daily partner to the customer, for global long term sustainable performances, Liebherr implements tailored solutions from technical support, spare parts and logistics solutions to global maintenance for all types of equipment, all over the world.

Customer Support

International Service Organization

The Liebherr Service Support has always been an important focus for the company. Complete service during all operating phases from machinery installation to problem solving, spare parts inventory and technical service. Our service team is close to our customers, delivering the best specific maintenance solution to reduce both equipment downtime and repair costs.

Complete Training Program

From fully trained technicians to a full team of certified field service engineers, Liebherr commits to provide you with world class training. Dedicated to mining, the Liebherr training team provides maintenance staff training programs to allow cost-efficient and safe operations.



Remanufacturing

Reduced Costs and Investment

Over the course of a mining machine's lifetime, major components must be replaced to ensure continued safety, productivity and reliability. The Liebherr Mining Reman Program offers customers an OEM alternative to purchasing brand new replacement components. Enabling customers to achieve lowest possible equipment lifecycle costs without compromising quality, performance or reliability.

Fast Availability

With an international service network and component facilities worldwide, component repair services and exchange components are available to customers regardless of the location of their Liebherr Mining equipment.



Parts Business

Performance

Using genuine Liebherr components ensures the best interaction within your machine, encouraging optimal performance and most effective machine operation. By using Liebherr genuine parts you can be sure that you are in line with the latest improvements and updates on parts and you are also provided with peace-of-mind with all major components being tracked in the Liebherr Maintenance Management System.

Partnership

Liebherr regularly reviews requirements for parts and components for individual machines, based on operating hours, consumption and planned maintenance, resulting in minimized down time for customers. With access to the Global stock via all Liebherr Mining Warehouses, you will improve productivity by having the part you need, when you need it.



Troubleshoot Advisor Platform

- Unique maintenance system to help you identify problems
- Easy and user-friendly interface
- Compatible with mobile, tablet or laptop
- Regular updating of the database
- Procedures described by specialist with images and videos

Repair and Remanufacturing Programs

- Liebherr certified quality
- As-new warranty
- OEM expertise
- Reduced costs and investment
- Fast availability

Easy Access Parts Online

- Available any time anywhere
- User-friendly interface
- Online ordering
- Save time and money



Safety



Protecting Your Most Important Assets

All dredging excavators provide uncompromising safety for operators and maintenance crews. Equipped with the service flap easily accessible from the front and integrating wide access, all dredging excavators offer quick and safe maintenance.

Safety-First Working Conditions

Safety-First Cab Design

The extra-large dredging cab offers ideal working conditions. Designed with a one-piece windscreen, the cab supplies large panoramic windows providing an outstanding visibility over the whole equipment. Two outside cameras allow a 360° view around the equipment. Long-distance lighting allows the operator to properly view his area of work for the most efficient loading.

Secure Maintenance

All components have been located allowing effortless inspection and replacement. Numerous service lights are strategically located in the service areas to sustain suitable maintenance conditions, day or night. Emergency stops have been strategically placed in the cab, engine compartment and at the front service station. The Liebherr dredging excavators eliminate hazards to ensure a safe environment for the service staff during maintenance.

Efficient Machine Protection

Automatic Fire Suppression System

The Liebherr dredging excavators can be equipped with a fully integrated fire suppression, employing a dual agent solution to prevent and protect the machine. The fire suppression system has both automatic and manual release capabilities, emergency stop devices are strategically located on the machine to be easily accessible in any case by the operator.

Defences to the Initiation of Fire

The engine compartment integrates a bulkhead wall that separates the engine from the hydraulic pumps. This reduces the risk of hydraulic oil entering the engine compartment. The turbochargers and exhaust systems are heat shielded, and all the hydraulic hoses are made from a highly resistant material to prevent the risk of fires.



Fire Fighting System (optional)

- Automatic active system against fire
- Fast access to shut down the machine

Working Environment Control

- Rear and side camera system
- LCD color screen to display cameras view
- 4 Long-range working halogen lights (LED in option)

Commitment to Employees Safety

- Safe and protected access to the components
- Major components centralized to be easily accessible
- Front service station
- E-stops located for the operator and maintenance staff
- Safe and protected access to the components and maintenance points thanks to platforms and handrails all around the machine



Mining Responsibly

Liebherr considers the preservation of the environment as a major challenge for the present and future. Liebherr takes greater account of environmental issues in designing, manufacturing and managing machine's structures. This commitment provides solutions that allow customers to balance high performance with environmental consciousness.

Reduce and Control Emissions

Optimized Energy Consumption, Fewer Emissions

The intelligent energy management system coordinates optimal interaction between the hydraulic system and engine output with the goal of a maximum performance with a minimum consumption. With the "Eco-Mode", the machine is set up to reduce engine load, improve significantly fuel consumption and optimize emissions.

Controlled Emission Rejection

The Liebherr-Dredging excavators offer fuel efficient operation meeting the latest emission standard in being powered with the USA/EPA IMO. They can be powered on request with the fuel-consumption optimized engine version. The Power Systems offer the best control of the machine impact on the environment contributing to cost efficiency without compromising productivity.

Sustainable Design and Manufacturing Process

Certified Environment Management Systems

Subject to the stringent European program for the regulation of the use of chemical substances in the manufacturing process REACH*, Liebherr undertakes a global evaluation to minimize the impacts of hazardous material, pollution control, water conservation, energy and environmental campaigns.

Extended Components and Fluids Lifetime

Liebherr is constantly working on ways to extend component life. Through the Exchange Components program, superior lubrication systems and the reinforcement of parts under stress, Liebherr can reduce frequency of part replacement. The result minimizes environmental impact and lowers the overall cost of ownership.

*REACH is the European Community Regulation on chemicals and their safe use (EC 1907/2006) It deals with the Registration, Evaluation, Authorization and Restriction of Chemical Substances.



Remanufacturing Program

- Second life for your major components
- Liebherr certified quality
- Reduced environmental impact
- Reduced costs and investment

Eco-Mode

- Improved fuel efficiency
- Less noise pollution
- Less dioxide carbon emissions

Sustainable Manufacturing Processy

- Promoted recovery-waste management
- Controlled non-recyclable waste elimination
- Eco-friendly material selection (95 % of material used on machine is recyclable)
- European certifications

100 t Class



P 9150

Operating Weight	120 tonnes/132 tons
Bucket Range	3.0 m ³ –7.8 m ³ /4 yd ³ –10.8 yd ³
Engine	565 kW/757 HP IMO 2
Digging Depth	up to 19.3 m/63 ft

Mid Size Class



	P 9200	P 9250	P9350
Operating Weight	160 tonnes/176 tons	215 tonnes/237 tons	270 tonnes/298 tons
Bucket Range	2.6 m ³ –8.3 m ³ / 3.4 yd ³ – 10.9 yd ³	2.5 m ³ –8.5 m ³ /3.3 yd ³ –11.1 yd ³	3.0 m ³ –15.3 m ³ /3.9 yd ³ –20.0 yd ³
Engine	810 kW/1,086 HP IMO 2	960 kW/1,287 HP IMO 2	1,120 kW/1,500 HP IMO 2
Digging Depth	up to 21.0 m/68.1 ft	up to 22.9 m/75.1 ft	up to 23.0 m/75.5 ft

Ultra Class



P 995

P 9800

Operating Weight	398 tonnes/439 tons	580 tonnes/639 tons
Bucket Range	7.0 m ³ –25.0 m ³ /11.1 yd ³ –32.7 yd ³	12.0 m ³ –30.0 m ³ /15.7 yd ³ –39.2 yd ³
Engine	1,750 kW/2,346 HP IMO 2	2,984 kW/4,000 HP IMO 2
Digging Depth	up to 26.3 m/86.3 ft	up to 27.3 m/89.6 ft

Technical Data



Engine

Designed for ambient temperature range from $-20\text{ }^{\circ}\text{C}$ up to $50\text{ }^{\circ}\text{C}/-4\text{ }^{\circ}\text{F}$ up to $122\text{ }^{\circ}\text{F}$ (with optional cold kit down to $-40\text{ }^{\circ}\text{C}/-40\text{ }^{\circ}\text{F}$)

Cooling	water-cooled with hydrostatic fan drive
Air cleaner	dry-type air cleaner with pre-cleaner, primary and safety elements, automatic dust discharge
Engine idling	electronically controlled
Fuel tank	26 hours operation



Electric System

Electric isolation	easy accessible battery isolation
Lightings	standard light package for 24 hours of operation
Floodlights	marine type 24 V floodlights made by Aqua Signal (LED)
Standstill heating	electrical cabinets and instrumentation boxes in the cabin equipped with 24 V standstill heaters to prevent water damage due to condensation
Electrical wiring	heavy duty execution in IP65 standard for operating conditions from $-50\text{ }^{\circ}\text{C}$ to $100\text{ }^{\circ}\text{C}/-58\text{ }^{\circ}\text{F}$ to $212\text{ }^{\circ}\text{F}$



Hydraulic System

High pressure safety filters after each high pressure pump (200 μm), full flow return filters (15/5 μm), leak oil filters (15/5 μm)

Hydraulic pump for attachment	variable flow axial piston pumps
Pump management	electronically controlled pressure and flow management with oil flow optimisation
Hydraulic cooler	separated cooler, temperature controlled fan driven via hydraulic piston motors
MODE selection	adjustment of machine performance and the hydraulics via a mode selector to match application
ECO	for economical operation (can be combined with fuel optimized setting)
POWER	for maximum digging power and heavy duty jobs



Pontoon Hydraulic Oil Supply

Design	a hydraulic rotary connection is installed on the excavator to supply hydraulic oil to the pontoon consumers
Flow control	the required oil capacity will be regulated by the pump oil flow regulators. An interfacing between the pontoon's hydraulic system and the excavator hydraulic system is provided



Hydraulic Controls

Power distribution	via monoblock control valves with integrated primary relief valves and flanged on secondary valves
Flow summation	to attachment
Closed-loop circuit	for uppercarriage swing drive
Electro-hydraulic servo control	
Attachment and swing	electronic optimized control via proportional valves



Swing Drive

Drive by	Liebherr axial piston motors
Transmission	Liebherr planetary reduction gears
Swing ring	Liebherr, sealed single race ball bearing swing ring, internal teeth
Swing speed	0 – 6 rpm (according to machine model)
Parking brake	wet multi-disc brakes, spring applied, hydraulically released



Elastic Foundation

Design	the excavator swing ring is mounted on the elastic foundation which is connected to the pontoon deck via oversized, torque resistant shock mounts designed for optimum force management. They absorb shocks and stresses created by the actions of the excavator as well as forces generated by wave action and barge movement
Fastening	bolted to the pontoon deck structure



Operator's Cab

Cab	sound insulated, tinted windows. Front window armored glass, side window sliding window
Operator's seat	air suspended, body-contoured with shock absorber, adjustable to operator's weight
Joysticks	joystick levers integrated into armrest of seat, armrest adjusted to seat position
Condition monitoring	machine condition monitoring system with error reporting and operational information
Rear vision system	camera installation on counterweight and right-hand side of the uppercarriage displayed over the LCD-display
Heating system	heavy duty, fully automatic, high output air conditioner and heater unit, contains fluorinated greenhouse gases HFC 134a with a Global Warming Potential (GWP) of 1430, the AC circuit contains 7.5 kg / 16.5 lb of HFC-134 representing an equivalent of 10.7 tonnes / 11.6 tons of CO ₂ , the 2 nd AC circuit (optional) contains 4.8 kg / 10.6 lb of HFC-134 representing an equivalent of 6.9 tonnes / 7.6 tons of CO ₂

Technical Data

Service Station (Centralized Couplings)

Quick release couplings are provided for:	<ul style="list-style-type: none"> – fuel filling – window wash water – engine oil draining and filling – hydraulic oil filling – SAT draining and filling – grease filling <p>all couplings in the service station are “Wiggins” type</p>
--	--

Central Lubrication System

Type	2 separate circuits, one for the entire attachment/swing ring bearing, another for the swing ring teeth
Grease pumps	hydraulic pump(s) for the attachment swing ring bearing hydraulic or electric pump for the swing ring teeth
Refill	via the service flap for both containers, fill line with grease filters

Attachment

Design	box-type structure with large steel castings in all high-stress areas, specifically designed for dredging applications stress relieved
Pivot points	fully sealed, all bearings equipped with wear resistant steel-bushings and connected to the central lubrication system (except on the P 9150)
Hydraulic cylinders	Liebherr designed with NiCr-plated (50/30 µm) piston rods, hydraulic piston cushioning to protect cylinders from shock, bucket cylinder rod guard to prevent damage from rocks (optional)
Drain plugs	boom and stick equipped with drain plugs
Service access	access ladder on the boom, service platforms on both sides of the boom to facilitate maintenance (except on the P 9150)
Hammer and grapple application	available (optional)

Fire Suppression System (Optional)

Automatic fire suppression system Powder/Foam manufactured by ANSUL according to the latest requirements, including local commissioning and approval by the manufacturer

Safety Systems

Emergency stop switches	<ul style="list-style-type: none"> – in hydraulic compartment – in engine compartment – in operator cab – inputs provided to the pontoon for external emergency stop switches – access ladder
Emergency control	emergency lowering of the attachment to the pontoon deck
Emergency boom lift package	the attachment can be raised from the sea-bed with stopped engine via a separate hydraulic pump provided by the owner. Hydraulic connections are provided for the hoist cylinders
Load holding valves on hoist cylinders	boom lowering control device

Marine Features

Corrosion protection coating	<ul style="list-style-type: none"> – maritime painting – galvanized catwalk and handrails (painting in option) – stainless steel greasing system
Hydraulic oil filtration	by-pass filters with water separator
Conservation	conservation corrosion protection
Splash water protection	the underside of the upper carriage is water-tight
Welding	all components are completely welded unless the access of certain structures does not allow for complete welds. These are sealed prior to painting to prevent the intrusion of water
Used oil tank	an oil collector is placed on the boom to drain the hydraulic hoses in a used oil tank placed in front of the excavator in case of attachment changing

P 9150

Bucket Range and Dimensions

Boom		Stick		Bucket size		Max depth		Work depth		Stroke at work depth		Digging force (SAE)		Breakout force (SAE)	
m	ft	m	ft	m ³	yd ³	m	ft	m	ft	m	ft	kN	lbf	kN	lbf
9.3	30.28	4.6	15.1	7.8	10.2	10.4	34.1	9.0	29.5	5.4	17.8	430.0	96,668	570	128,141
		5.7	18.7	7.0	9.2	11.4	37.4	10.0	32.8	6.1	20.0	374.5	84,191	570	128,141
		7.0	22.9	6.0	7.8	12.5	41.0	11.0	36.1	6.5	21.3	328.0	73,737	395	88,800
11.5	37.80	5.7	18.7	5.6	7.3	13.6	44.7	12.0	39.4	6.9	22.7	383.0	86,102	395	88,800
		7.0	22.9	5.2	6.8	14.9	49.0	13.0	42.7	8.0	26.2	330.0	74,187	395	88,800
		8.4	27.6	4.6	6.0	16.1	52.1	15.0	49.2	6.1	20.0	292.0	65,644	430	96,668
14.0	45.94	7.0	22.1	3.2	4.2	17.0	55.9	16.0	52.5	5.2	17.0	335.0	75,311	430	96,668
		8.4	27.6	3.0	3.9	18.5	60.8	17.0	55.9	7.2	23.9	292.0	65,644	430	96,668
		9.5	31.2	3.0	3.9	19.3	63.3	18.0	59.1	6.8	22.3	272.0	61,148	290	65,195

Distance between water level and base plate = 1 m/3'3"

Considered bulk density: 1.8 t/m³/3,035 lb/yd³

Volumes are calculated without any attachment option (extra hydraulic, protections ...).

If options impacting the total mass of the attachment are selected, the bucket volumes will decrease accordingly.

Considered bucket protection: standard HD

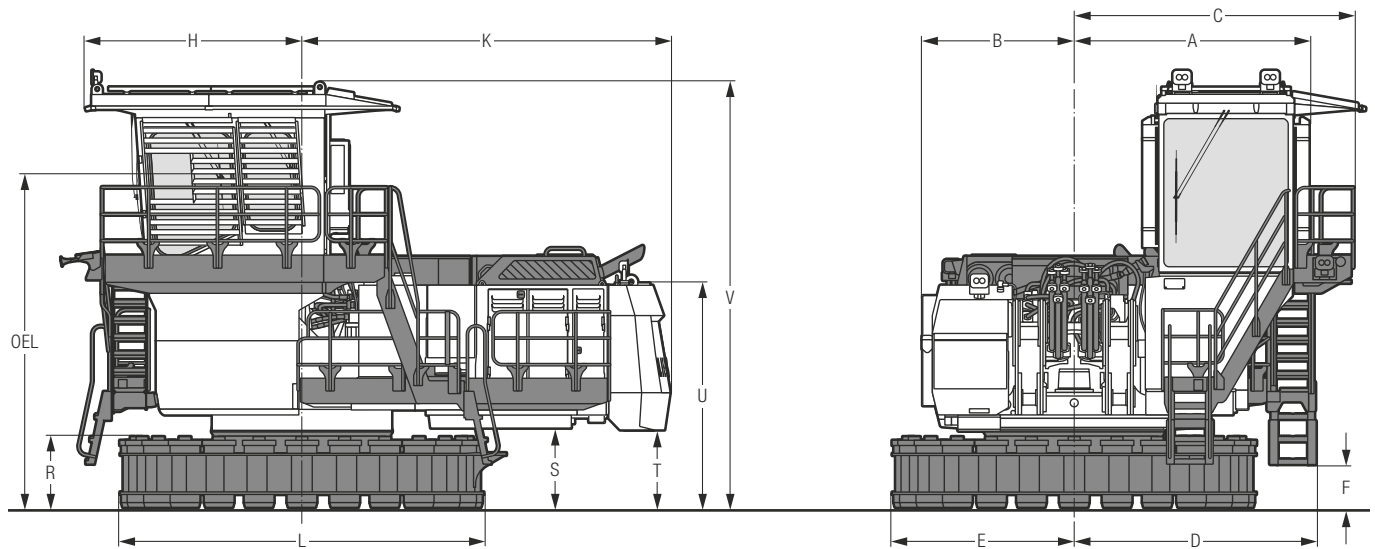

	mm/ft in
A	2,350/ 7'7"
B	2,100/ 6'9"
C	3,950/ 13'
D	3,300/ 10'8"
E	2,525/ 8'3"
F	580/ 1'9"
H	3,050/ 10'
K	5,060/ 16'6"

	mm/ft in
L	5,050/ 16'6"
R	971/ 3'2"
S	1,225/ 4'
T	1,065/ 3'5"
U	3,080/ 10'1"
V	5,800/ 19'
OEL	Operator's eye level 4,580/ 15'

P 9200

Bucket Range and Dimensions

Boom		Stick		Bucket size		Max depth		Work depth		Stroke at work depth		Digging force (SAE)		Breakout force (SAE)	
m	ft	m	ft	m ³	yd ³	m	ft	m	ft	m	ft	kN	lbf	kN	lbf
14.0	45.11	5.0	16.4	8.3	10.9	14.0	48.2	12.0	39.4	5.6	21.7	566	127,242	466	104,761
		6.7	23.3	7.0	9.2	15.4	53.1	14.0	49.2	6.9	22.1	474	106,559	514	115,552
		8.5	36.1	5.9	7.7	17.2	59.0	16.0	52.5	7.3	27.9	390	87,675	514	115,552
16.0	52.50	6.7	21.1	5.2	6.8	17.3	59.0	16.0	52.5	6.4	21.3	474	106,559	514	115,552
		8.5	27.1	4.2	5.5	19.0	65.3	18.0	59.0	6.5	25.3	395	88,800	522	117,350
		10.1	33.1	3.7	4.8	20.5	69.1	19.0	65.7	9.1	21.1	345	77,559	544	122,296
18.0	59.00	6.7	23.3	3.5	4.6	18.8	64.7	18.0	59.0	5.0	17.4	487	109,482	568	127,691
		8.5	27.1	3.0	3.9	20.5	70.6	19.0	62.3	8.3	30.2	407	91,497	593	133,312
		10.1	33.1	2.6	3.4	22.0	74.9	21.0	68.1	7.3	28.2	356	80,032	622	139,831

Distance between water level and base plate = 1 m/3'3"

Considered bulk density: 1.8 t/m³/3,035 lb/yd³

Volumes are calculated without any attachment option (extra hydraulic, protections ...).

If options impacting the total mass of the attachment are selected, the bucket volumes will decrease accordingly.

Considered bucket protection: standard HD

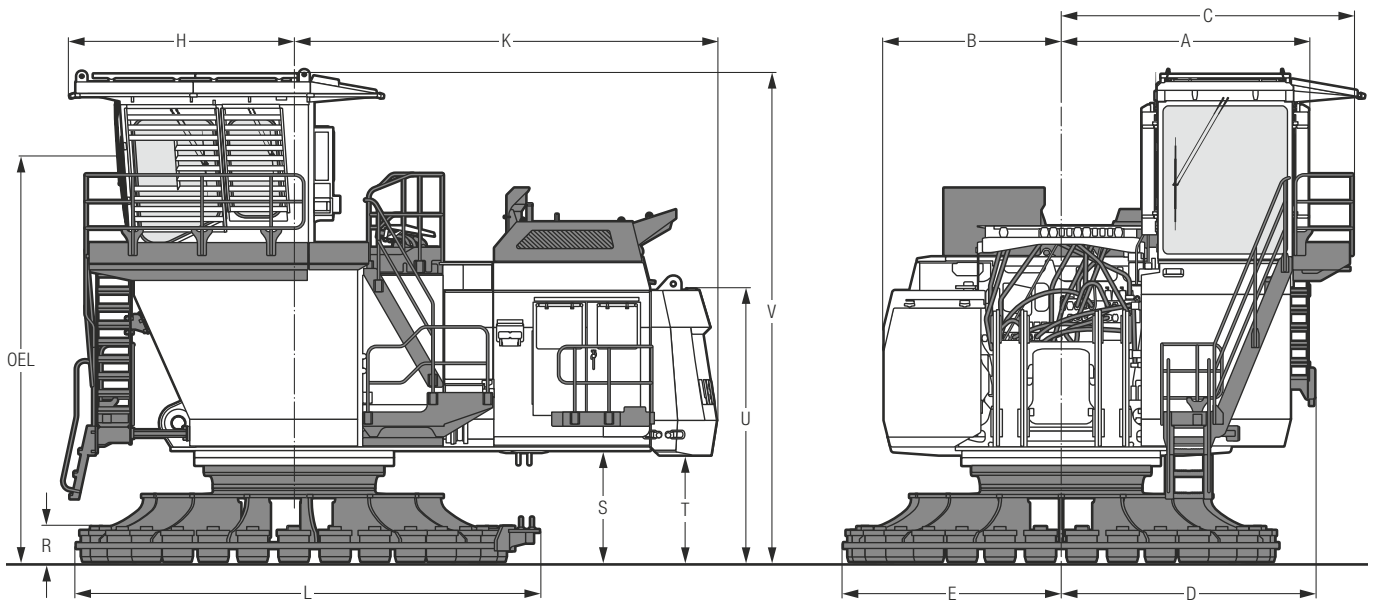

	mm/ft in
A	3,400/11'6"
B	2,430/ 7'9"
C	4,150/13'6"
D	3,560/11'7"
E	2,975/ 9'8"
H	3,080/10'1"
K	5,800/19'

	mm/ft in
L	6,295/ 20'6"
R	750/ 2'5"
S	1,350/ 4'4"
T	1,290/ 4'2"
U	3,570/11'7"
V	6,530/21'4"
OEL	Operator's eye level 5,350/15'5"

P 9250

Bucket Range and Dimensions

Boom		Stick		Bucket size		Max depth		Work depth		Stroke at work depth		Digging force (SAE)		Breakout force (SAE)	
m	ft	m	ft	m ³	yd ³	m	ft	m	ft	m	ft	kN	lbf	kN	lbf
14.8	48.6	6.00	19.7	7.2	9.4	15.9	52.2	14.0	45.9	6.60	21.7	620	139,382	750	168,607
		7.10	23.3	8.5	11.1	16.7	54.8	15.0	49.2	6.80	22.1	558	125,443	550	123,645
		9.45	31.0	7.0	9.2	19.0	62.3	18.0	59.1	6.60	21.7	451	101,389	550	123,645
		11.00	36.1	5.5	7.2	20.4	66.9	19.0	62.3	8.50	27.9	404	90,823	550	123,645
16.5	54.1	6.00	19.7	4.5	5.9	18.1	59.4	16.0	52.5	7.00	23.0	620	139,382	750	168,607
		7.10	23.3	6.5	8.5	18.9	62.0	17.0	55.8	7.00	23.0	558	125,443	550	123,645
		9.45	31.0	3.9	5.1	21.2	69.6	20.0	65.6	6.60	21.7	451	101,389	550	123,645
		11.00	36.1	3.2	4.2	22.5	73.8	22.0	72.2	4.25	13.9	404	90,823	550	123,645
18.0	59.1	7.10	23.3	3.5	4.6	20.7	67.9	19.0	62.3	6.70	22.0	550	123,645	550	123,645
		9.45	31.0	2.5	3.3	22.9	75.1	22.0	72.2	6.40	21.0	451	101,389	550	123,645

Distance between water level and base plate = 1 m/3'3"

Considered bulk density: 1.8 t/m³/3,035 lb/yd³

Volumes are calculated without any attachment option (extra hydraulic, protections ...).

If options impacting the total mass of the attachment are selected, the bucket volumes will decrease accordingly.

Considered bucket protection: standard HD

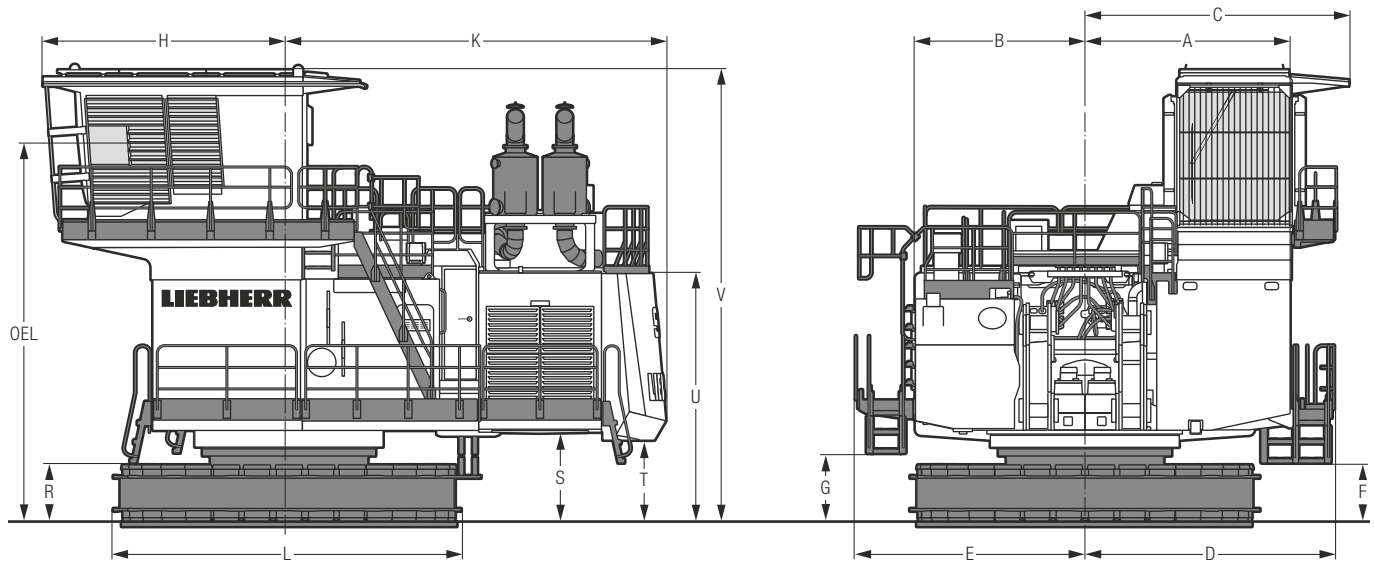

	mm/ft in
A	3,320/10'10"
B	2,750/ 9'
C	4,285/14'
D	4,050/13' 3"
E	3,725/12' 2"
F	950/ 3' 1"
G	1,105/ 3' 7"
H	3,890/12' 9"

	mm/ft in
K	6,190/20'3"
L	5,640/18'5"
R	920/ 3'
S	1,530/ 5'
T	1,400/ 4'7"
U	4,100/15'8"
V	7,400/24'3"
OEL	Operator's eye level 6,130/20'1"

P 9350

Bucket Range and Dimensions

Boom		Stick		Bucket size		Max depth		Work depth		Stroke at work depth		Digging force (SAE)		Breakout force (SAE)	
m	ft	m	ft	m ³	yd ³	m	ft	m	ft	m	ft	kN	lbf	kN	lbf
12.0	39.4	4.20	13.8	15.3	20.0	11.7	38.4	10.0	32.8	5.5	18.0	870	195,584	1,020	229,305
		6.50	21.3	13.5	17.7	14.0	45.9	12.0	39.4	6.4	21.0	675	151,746	1,020	229,305
15.0	49.2	4.00	13.1	8.0	10.5	13.9	45.6	12.0	39.4	6.3	20.7	965	216,941	980	220,313
		6.50	21.3	7.0	9.2	16.4	53.8	14.0	45.9	6.0	19.7	712	160,064	980	220,313
		7.10	23.3	9.0	11.8	16.9	55.4	15.0	49.2	7.1	23.3	652	146,575	520	116,901
		9.45	31.0	8.0	10.5	19.2	63.0	18.0	59.1	7.0	23.0	526	118,249	520	116,901
19.0	62.3	7.10	23.3	5.0	6.5	20.6	67.6	19.0	62.3	6.9	22.6	567	127,467	550	123,645
		9.45	31.0	3.0	3.9	23.0	75.5	22.0	72.2	6.5	21.3	456	102,513	550	123,645

Distance between water level and base plate = 1 m/3'3"

Considered bulk density: 1.8 t/m³/3,035 lb/yd³

Volumes are calculated without any attachment option (extra hydraulic, protections ...).

If options impacting the total mass of the attachment are selected, the bucket volumes will decrease accordingly.

Considered bucket protection: standard HD

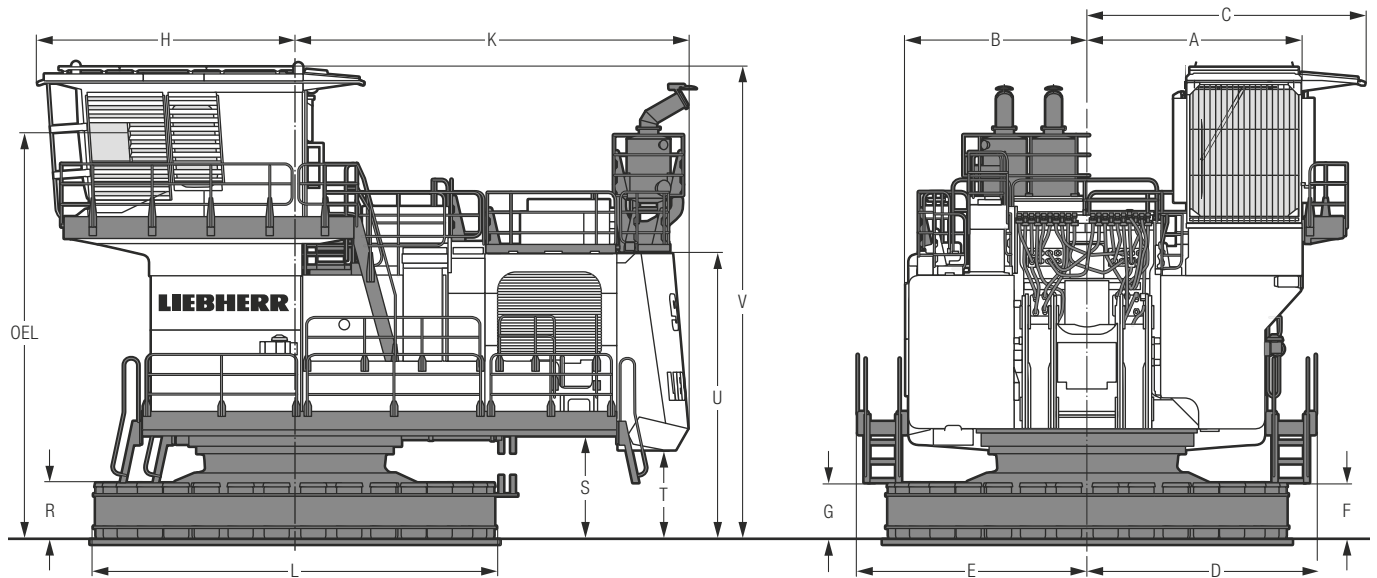

	mm/ft in
A	2,950/ 9' 8"
B	3,505/11' 5"
C	4,530/14'10"
D	3,745/12' 3"
E	3,745/12' 3"
F	925/ 3'
G	925/ 3'
H	4,190/13' 8"

	mm/ft in
K	6,400/20'11"
L	6,560/21' 6"
R	925/ 3'
S	1,680/ 5' 6"
T	1,455/ 4' 9"
U	4,655/15' 8"
V	7,700/25' 3"
OEL	Operator's eye level 6,625/21' 8"

P 995

Bucket Range and Dimensions

Boom		Stick		Bucket size		Max depth		Work depth		Stroke at work depth		Digging force (SAE)		Breakout force (SAE)	
m	ft	m	ft	m ³	yd ³	m	ft	m	ft	m	ft	kN	lbf	kN	lbf
13.5	44.3	4.5	14.8	25.0	32.7	13.4	44.0	11.0	36.1	6.5	21.3	1,160	260,778	1,270	285,507
		6.5	21.3	18.0	23.5	15.0	49.2	13.0	42.7	7.5	24.6	965	216,940	805	180,971
		8.0	26.2	16.5	21.6	16.5	54.1	15.0	49.2	5.9	19.4	840	188,889	825	185,467
		9.6	31.5	15.3	20.0	18.0	59.1	16.0	52.5	8.5	27.9	740	166,358	855	192,211
16.0	52.5	4.5	14.8	13.0	17.0	16.2	53.2	14.0	45.9	7.2	23.6	1,160	260,778	1,270	285,507
		6.5	21.3	14.5	19.0	18.0	59.1	16.0	52.5	6.7	22.0	975	219,188	825	185,467
		8.0	26.2	13.0	17.0	19.2	63.0	18.0	59.1	5.5	18.0	850	191,087	830	186,591
		9.6	31.5	11.0	14.4	21.0	68.9	20.0	65.6	4.8	15.7	735	165,234	830	186,591
19.0	62.3	6.5	21.3	9.0	11.8	20.6	67.6	18.0	59.1	6.1	20.0	1,015	228,181	975	219,188
		8.0	26.2	8.0	10.5	21.8	71.5	20.0	65.6	7.9	25.9	885	198,955	945	212,444
		9.6	31.5	7.0	9.2	23.6	77.4	22.0	72.2	6.4	21.0	755	169,730	890	200,080
22.0	72.2	9.5	31.2	8.5	11.1	26.3	86.3	24.0	78.7	8.4	27.6	450	101,164	575	129,265

Distance between water level and base plate = 1 m/3'3"

Considered bulk density: 1.8 t/m³/3,035 lb/yd³

Volumes are calculated without any attachment option (extra hydraulic, protections ...).

If options impacting the total mass of the attachment are selected, the bucket volumes will decrease accordingly.

Considered bucket protection: standard HD

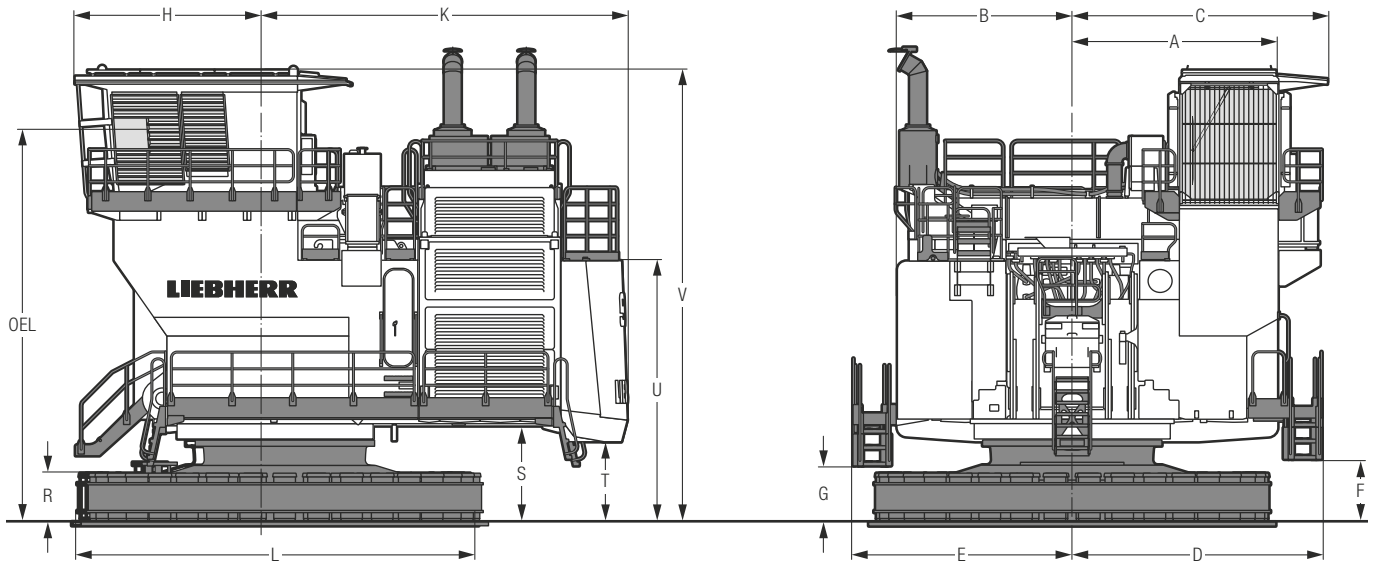

	mm/ft in
A	3,900/12' 9"
B	3,315/10'10"
C	4,830/15'10"
D	4,730/15' 6"
E	4,155/13' 7"
F	1,185/ 3'10"
G	1,060/ 3' 5"
H	3,520/11' 6"

	mm/ft in
K	6,925/22' 8"
L	7,500/24' 7"
R	920/ 3'
S	1,860/ 6' 1"
T	1,515/ 4'11"
U	4,940/15' 8"
V	8,565/28' 1"
OEL	Operator's eye level 7,500/24' 7"

P 9800

Bucket Range and Dimensions

Boom		Stick		Bucket size		Max depth		Work depth		Stroke at work depth		Digging force (SAE)		Breakout force (SAE)	
m	ft	m	ft	m ³	yd ³	m	ft	m	ft	m	ft	kN	lbf	kN	lbf
18.0	59.0	7.5	24.6	34.0	44.5	17.9	58.7	16.0	52.5	7.0	22.9	1,300	292,252	1,560	350,702
		12.0	39.4	23.0	30.1	21.7	71.2	20.0	65.6	8.1	26.6	980	220,313	940	211,320
22.0	72.2	7.5	24.6	17.0	22.2	21.9	71.9	20.0	65.6	6.0	19.7	1,300	292,252	1,640	368,687
		12.0	39.4	18.0	23.5	25.8	84.6	24.0	78.7	8.6	28.2	980	220,313	940	211,320
		14.0	45.9	15.3	20.0	27.9	91.5	26.0	85.3	9.3	30.5	870	195,584	940	211,320

Distance between water level and base plate = 1 m/3'3"

Considered bulk density: 1.8 t/m³/3,035 lb/yd³

Volumes are calculated without any attachment option (extra hydraulic, protections ...).

If options impacting the total mass of the attachment are selected, the bucket volumes will decrease accordingly.

Considered bucket protection: standard HD